

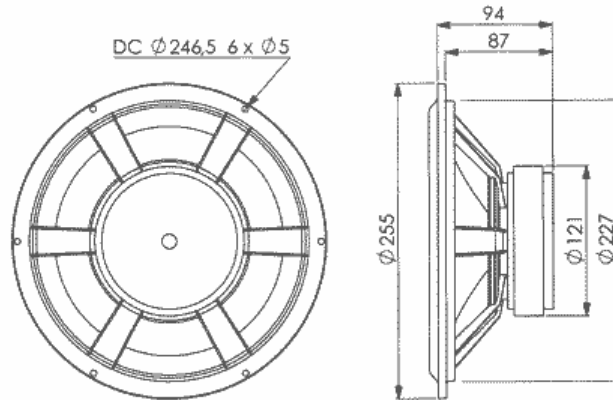

## 25W/8565-00

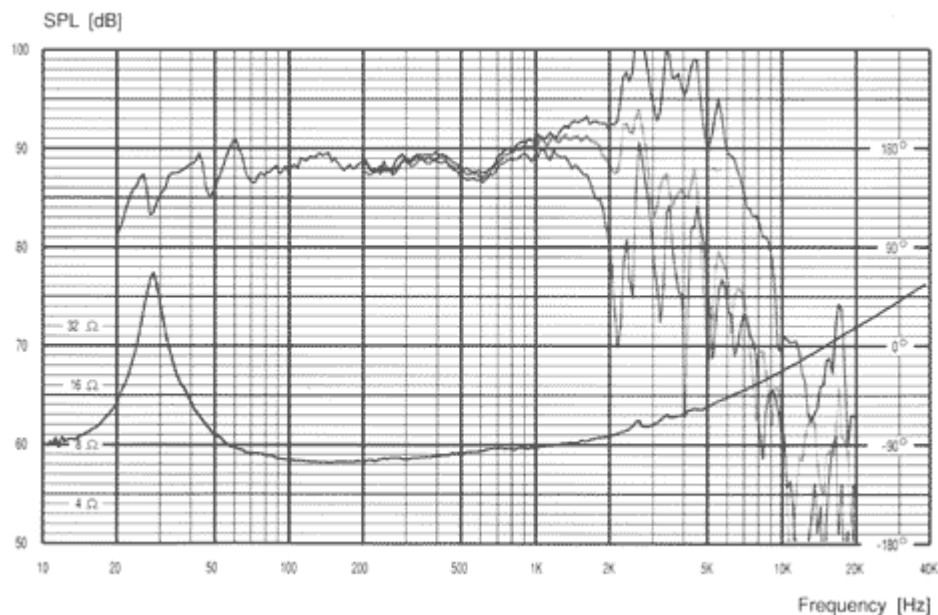

Characteristic sensitivity (2.83V / 1m)	: 88 dB
Recommended frequency range	: 20 - 600 Hz
Free air resonance frequency, $f_s$	: 20 Hz
DC resistance, $R_e$	: 5.5 ohm
Voice coil inductance, $L_e$	: 0.4 mH
Effective piston area, $S_d$	: 330 cm <sup>2</sup>
Moving mass incl. air, $m_d$	: 43 g
Mechanical loss, $R_m$	: 1.0 Ns/m
Force factor, $BL$	: 8.2 Tm
Equivalent volume, $V_{as}$	: 229 ltr.
Mechanical Q-factor, $Q_{ms}$	: 5.4
Electrical Q-factor, $Q_{es}$	: 0.44
Total Q-factor, $Q_{ts}$	: 0.41
Excursion, lin./max.	: $\pm 6.5 / \pm 12$ mm
Voice coil diameter	: 42 mm
Rated power handling	: 100 W
Net weight	: 2.6 kg



**Frequency response: 2.83V / 1m**